

GPS-1195 Smart Gate

The GPS 1195 is part of a full line of high speed automatic rising barriers designed for access and revenue control systems for public, private and industrial sites. Built for heavy-duty use and reliability our range can service lanes up to 23ft., while providing dependable efficient control and safe every day use.



GPS-1195

High speed automatic rising barriers designed for access and revenue control systems for public, private and industrial sites.

- > **Barrier gate arm:** Extruded aluminum arm, 31/4" round up to 23ft., optional arm styles available in wood up to 12ft and rectangular aluminum up to 12ft. Highly flexible polycarbonate arm up to a 10ft length. Folding arms available
- > **Vehicle detection:** The GPS-1195 barrier gate can hold up to 3 vehicle detectors for arming, Vend and Reset functions.
- > **Mounting:** The barrier can be mounted to a concrete pad or a pre-fabricated foundation using 4 wedge anchors 3/8" x 3 3/4".
- > **Durability:** Barrier arms are made of 10 gauge Satin coat steel and finished in a Tiger Drylac finish with zinc rich primer undercoat for durability and shine. The PLC controller is completely fuse protected against power surges.
- > **Warranty:** 1-year parts.
- > **Options:** Flashing lights, Internal or external safety edge, custom programs, the PLC controller can be interlinked with other GPS PLC controllers to communicate to each other.

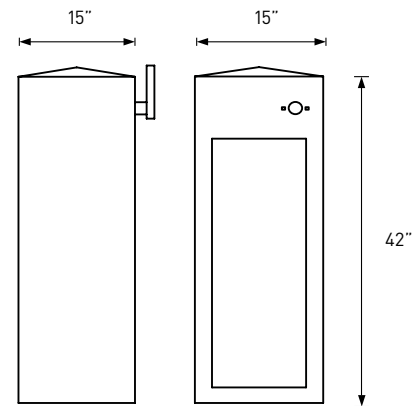

Technical characteristics:

Power supply:	120vac, single phase, frequency 50-60hz. Main power internal on/off switch c/w a 5 amp service outlet. Reversing motor 1/3hp – 1625 rpm
Open/close time:	2-3.7 seconds
Operating temp.:	-50 to + 70 C (-xx to 150 F)
Net weight:	240 pounds



Features:

- The standard GPS detector is the LMA1250HV 11 pin boxed detector to detect all vehicles including motorcycles and high bed vehicles.
- Nickel zinc coating applied to all internal shafts for long life protection against corrosion
- GPS products are available in all RAL color choices
- A DBK 500W fan forced heater c/w a DBK dial thermostat
- PLC controller c/w 26 I/O
- Plug and Play controller (no on site programming required)
- The PLC works in either 120v or 240v applications
- Removable plug screw terminal connectors
- Built in 24vdc, 200Ma power supply for radio receivers
- All inputs switch low voltage 24Vdc
- All outputs are isolated dry contacts
- On board manual up / down toggle switch
- Easily adaptable to existing field connections
- Inputs are protected
- Without the additional module GPS can daisy link up to 16 barrier gates for communications
- RS 232 Port, RS 485 Port
- Built in 7 day timer, Flasher, Real time clock, Battery backup for the PLC, etc.
- Accommodates 24vac and 120vac 11 pin boxed detectors
- Warranty: 1-year parts

Options

- 24vac/24vdc din rail mount power supply 1.2 amp
- Plug in module for an Ethernet connection
- Plug in module to daisy link 99 barrier gates for communications
- Proximity sensors for vehicle detection
- High intensity Red LED or Amber Flashing lights for barrier arms, easily seen in direct sunlight
- External Smart contactless safety edge
- S.O.S Package
- Endless variety of custom program capabilities
- UPS to raise barrier arm in case of a power failure
- UPS also used for full day battery operation (6000 cycles)

